



Precision, Quad, SPST Analog Switches

MAX364/MAX365

General Description

The MAX364/MAX365 are precision, quad, single-pole single-throw (SPST) analog switches. The MAX364 has four normally closed (NC), and the MAX365 has four normally open (NO) switches. Both parts offer low-channel on resistance (less than 85Ω), guaranteed to match within 2Ω between channels and to remain flat over the analog signal range (Δ9Ω max). Both parts also offer low leakage (less than 500pA at +25°C and less than 4nA at +85°C) and fast switching (turn-on time less than 250ns and turn-off time less than 170ns).

The MAX364/MAX365 are fabricated with Maxim's new improved 44V silicon-gate process. Design improvements guarantee extremely low charge injection (10pC), low power consumption (35μW), and electrostatic discharge (ESD) greater than 2000V. The 44V maximum breakdown voltage allows rail-to-rail analog signal handling capability.

These monolithic switches operate with a single positive supply (+10V to +30V) or with split supplies (±4.5V to ±20V) while retaining CMOS-logic input compatibility and fast switching. CMOS inputs provide reduced input loading.

Applications

Sample-and-Hold Circuits	Communication Systems
Guidance and Control Systems	Battery-Operated Systems
Heads-Up Displays	PBX, PABX
Test Equipment	Military Radios

Features

- ♦ **Low On Resistance:** < 45Ω Typical (85Ω Max)
- ♦ **Guaranteed Matched On Resistance Between Channels:** < 2Ω
- ♦ **Guaranteed Flat On Resistance over Full Analog Signal Range:** Δ9Ω Max
- ♦ **Guaranteed Charge Injection:** < 10pC
- ♦ **Guaranteed Off-Channel Leakage:** < 4nA at +85°C
- ♦ **ESD Guaranteed > 2000V per Method 3015.7**
- ♦ **Single-Supply Operation (+10V to +30V)**
Bipolar-Supply Operation (±4.5V to ±20V)
- ♦ **TTL-/CMOS-Logic Compatible**
- ♦ **Rail-to-Rail Analog Signal Handling Capability**

Ordering Information

PART	TEMP. RANGE	PIN-PACKAGE
MAX364CPE	0°C to +70°C	16 Plastic DIP
MAX364CSE	0°C to +70°C	16 Narrow SO
MAX364C/D	0°C to +70°C	Dice*
MAX364EGE	-40°C to +85°C	16 QFN
MAX364EPE	-40°C to +85°C	16 Plastic DIP
MAX364ESE	-40°C to +85°C	16 Narrow SO
MAX365CPE	0°C to +70°C	16 Plastic DIP
MAX365CSE	0°C to +70°C	16 Narrow SO
MAX365C/D	0°C to +70°C	Dice*
MAX365EGE	-40°C to +85°C	16 QFN
MAX365EPE	-40°C to +85°C	16 Plastic DIP
MAX365ESE	-40°C to +85°C	16 Narrow SO

* Contact factory for dice specifications.

Pin Configurations/Functional Diagrams/Truth Tables

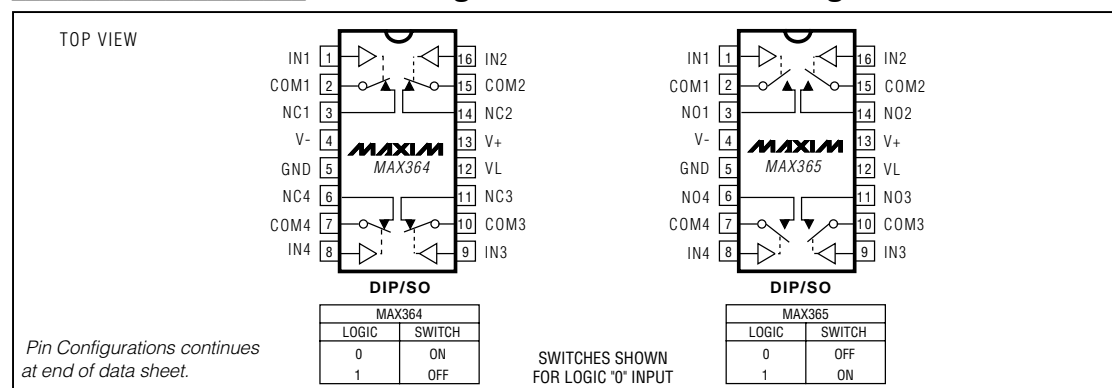
MAXIM

Maxim Integrated Products 1

For pricing, delivery, and ordering information, please contact Maxim/Dallas Direct! at 1-888-629-4642, or visit Maxim's website at www.maxim-ic.com.

Precision, Quad, SPST Analog Switches

ABSOLUTE MAXIMUM RATINGS

Voltage Referenced to V-

V+	44V
GND	25V
VL	(GND - 0.3V) to (V+ + 0.3V)
IN_, COM_, NO_, or NC_	(V- - 2V) to (V+ + 2V) or 30mA (whichever occurs first)
Continuous Current (any terminal)	30mA
Peak Current COM_, NO_, or NC_ (pulsed at 1ms, 10% duty cycle max)	100mA
ESD	2000V

Continuous Power Dissipation (T_A = +70°C) (Note 1)

Plastic DIP (derate 10.53mW/°C above +70°C)	842mW
QFN (derate 19.2mW/°C above +70°C)	1538mW
Narrow SO (derate 8.70mW/°C above +70°C)	696mW

Operating Temperature Ranges:

MAX36_C_	0°C to +70°C
MAX36_E_	-40°C to +85°C
Storage Temperature Range	-65°C to +150°C
Lead Temperature (soldering, 10sec)	+300°C

Note 1: All leads are soldered or welded to PC board.

Stresses beyond those listed under "Absolute Maximum Ratings" may cause permanent damage to the device. These are stress ratings only, and functional operation of the device at these or any other conditions beyond those indicated in the operational sections of the specifications is not implied. Exposure to absolute maximum rating conditions for extended periods may affect device reliability.

ELECTRICAL CHARACTERISTICS—Dual Supplies

(V+ = 15V, V- = -15V, VL = 5V, GND = 0V, V_{INH} = 2.4V, V_{INL} = 0.8V, T_A = T_{MIN} to T_{MAX}, unless otherwise noted.)

PARAMETER	SYMBOL	CONDITIONS	MIN	TYP (Note 2)	MAX	UNITS
ANALOG						
Analog-Signal Range	V _{COM_} , V _{NO_} , V _{NC}	(Note 3)	-15		15	V
On Resistance	R _{ON}	COM_ to NO_ or NC_, I _{COM} = -10mA, V _{COM} = 8.5V or -8.5V, V+ = 13.5V, V- = -13.5V	T _A = +25°C		50	85
			T _A = T _{MIN} to T _{MAX}			100
On Resistance Match Between Channels (Note 4)	R _{ON}	I _{COM} = -10mA, V _{COM} = 10V or -10V, V+ = 15V, V- = -15V	T _A = +25°C			2
			T _A = T _{MIN} to T _{MAX}			4
On Resistance Flatness (Note 4)	R _{ON}	I _{COM} = -10mA, V _{COM} = 5V or -5V, V+ = 15V, V- = -15V	T _A = +25°C			9
			T _A = T _{MIN} to T _{MAX}			15
NC_ or NO_ Leakage Current	I _{NO_} , I _{NC}	NO_ or NC_ terminal, V _{COM} = ±15.5V, V _{NO} or V _{NC} = ±15.5V, V+ = 16.5V, V- = -16.5V	T _A = +25°C		-0.50	0.01 0.50
			T _A = T _{MIN} to T _{MAX}		-4	4
COM_ Off Leakage Current	I _{NO} , I _{NC}	COM_ terminal, V _{NO} or V _{NC} = ±15.5V, V _{COM} = +15.5V, V+ = 16.5V, V- = -16.5V	T _A = +25°C		-0.50	0.01 0.50
			T _A = T _{MIN} to T _{MAX}		-4	4
COM_, NC_ or NO_ On Leakage Current	I _{COM} or I _{NO} , I _{NC}	COM_ to NC_ or NO_ terminal, V _{COM} = ±15.5V, V _{NO} or V _{NC} = ±15.5V, V+ = 16.5V, V- = -16.5V	T _A = +25°C		-0.50	0.08 0.50
			T _A = T _{MIN} to T _{MAX}		-6	6
INPUT						
Input Current with Input Voltage High	I _{INH}	V _{IN_} = 2.4V, all others = 0.8V	-0.5	-0.00001	0.5	αA
Input Current with Input Voltage Low	I _{INL}	V _{IN_} = 0.8V, all others = 2.4V	-0.5	-0.00001	0.5	αA

Precision, Quad, SPST Analog Switches

MAX364/MAX365

ELECTRICAL CHARACTERISTICS—Dual Supplies (continued)

(V+ = 15V, V- = -15V, VL = 5V, GND = 0V, VINH = 2.4V, VINL = 0.8V, TA = TMIN to TMAX, unless otherwise noted.)

PARAMETER	SYMBOL	CONDITIONS		MIN	TYP (Note 2)	MAX	UNITS
SUPPLY							
Power-Supply Range	V+, V-			±4.5		±20.0	V
Positive Supply Current	I+	All channels on or off, VIN = 0V or 5V, V+ = 16.5V, V- = -16.5V	TA = +25°C	-1	0.001	1	µA
			TA = TMIN to TMAX	-5		5	
Negative Supply Current	I-	All channels on or off, VIN = 0V or 5V, V+ = 16.5V, V- = -16.5V	TA = +25°C	-1	-0.0001	1	µA
			TA = TMIN to TMAX	-5		5	
Logic Supply Current	IL	All channels on or off, VIN = 0V or 5V, V+ = 16.5V, V- = -16.5V	TA = +25°C	-1	0.001	1	µA
			TA = TMIN to TMAX	-5		5	
Ground Current	IGND	All channels on or off, VIN = 0V or 5V, V+ = 16.5V, V- = -16.5V	TA = +25°C	-1	-0.0001	1	µA
			TA = TMIN to TMAX	-5		5	
DYNAMIC							
Turn-On Time	ton	VNO or VNC = ±10V, Figure 2	TA = +25°C		150	250	ns
Turn-Off Time	toff	MAX364, VNO or VNC = ±10V, Figure 2	TA = +25°C		90	120	ns
		MAX365, VNO or VNC = ±10V, Figure 2	TA = +25°C		110	170	ns
Charge Injection	Q	CL = 1nF, VGEN = 0V, RGEN = 0Ω, Figure 3	TA = +25°C		5	10	pC
Off Isolation (Note 5)	OIRR	RL = 50Ω, CL = 5pF, f = 1MHz, Figure 4	TA = +25°C		60		dB
Crosstalk (Note 6)		RL = 50Ω, CL = 5pF, f = 1MHz, Figure 5	TA = +25°C		100		dB
NC_ or NO_ Off Capacitance	C(OFF)	f = 1MHz, Figure 6	TA = +25°C		4		pF
COM_ Off Capacitance	CCOM(OFF)	f = 1MHz, Figure 6	TA = +25°C		4		pF
Channel-On Capacitance	CCOM(ON)	f = 1MHz, Figure 6	TA = +25°C		16		pF

Precision, Quad, SPST Analog Switches

MAX364/MAX365

ELECTRICAL CHARACTERISTICS—Single Supply

(V+ = 12V, V- = 0V, VL = 5V, GND = 0V, VINH = 2.4V, VINL = 0.8V, TA = TMIN to TMAX, unless otherwise noted.)

PARAMETER	SYMBOL	CONDITIONS		MIN	TYP (Note 2)	MAX	UNITS
ANALOG							
Analog Signal Range	VCOM_, VNO_, VNC_	(Note 3)		0		12	V
On Resistance	RON	COM_ to NO_ or NC_, INC or INO = -10mA, VL = 5.25V, VCOM = 3V, 8V, V+ = 10.8V	TA = +25°C		100	160	Ω
			TA = TMIN to TMAX			200	
SUPPLY							
Power-Supply Range	V+, V-			10.8		24.0	V
Power-Supply Current	I+	All channels on or off, VIN = 0V or 5V	TA = +25°C	-1	0.001	1	μA
			TA = TMIN to TMAX	-5		5	
Negative Supply Current	I-	All channels on or off, VIN = 0V or 5V	TA = +25°C	-1	-0.0001	1	μA
			TA = TMIN to TMAX	-5		5	
Logic Supply Current	IL	All channels on or off, VIN = 0V or 5V	TA = +25°C	-1	0.001	1	μA
			TA = TMIN to TMAX	-5		5	
Ground Current	IGND	All channels on or off, VIN = 0V or 5V	TA = +25°C	-1	-0.0001	1	μA
			TA = TMIN to TMAX	-5		5	
DYNAMIC							
Turn-On Time	tON	VNC or VNO = 8V, Figure 2	TA = +25°C		300	400	ns
Turn-Off Time	tOFF	VNC or VNO = 8V, Figure 2	TA = +25°C		60	200	ns
Charge Injection	Q	CL = 1nF, VGEN = 0V, RGEN = 0Ω, Figure 3	TA = +25°C		5	10	pC

Note 2: The algebraic convention, where the most negative value is a minimum and the most positive value a maximum, is used in this data sheet.

Note 3: Guaranteed by design.

Note 4: On resistance match between channels and flatness are guaranteed only with bipolar-supply operation.

Note 5: See Figure 2. Off Isolation = $20 \log_{10} \left(\frac{V_{COM}}{V_{NC} \text{ or } V_{NO}} \right)$, VCOM = output, VNO or VNC = input to off switch.

Note 6: Between any two switches. See Figure 5.

Precision, Quad, SPST Analog Switches

Typical Operating Characteristics

($T_A = +25^\circ\text{C}$, unless otherwise noted.)

MAX364/MAX365

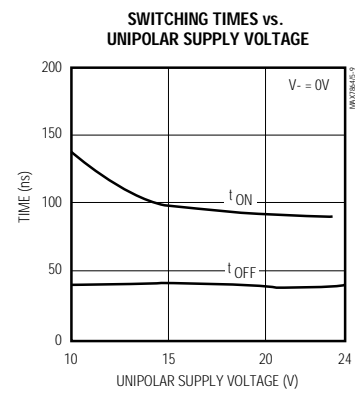
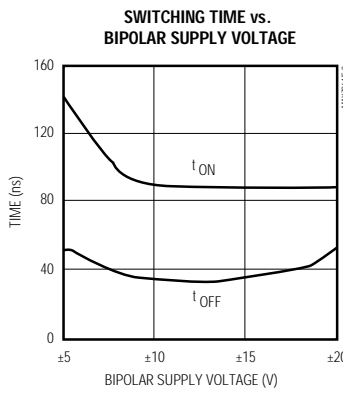
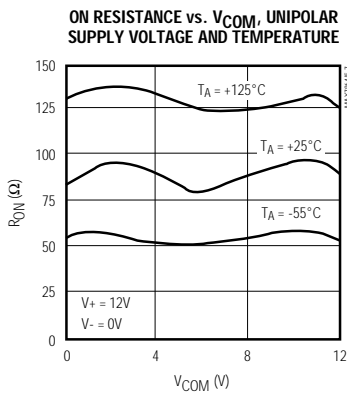
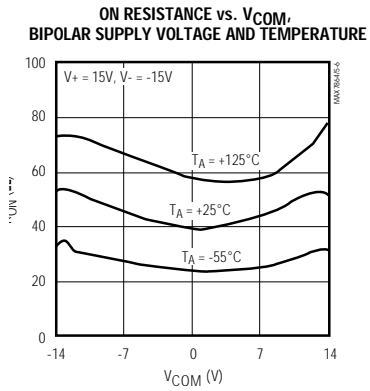
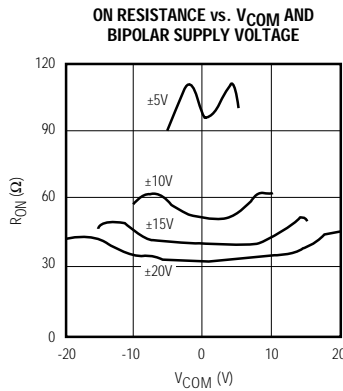
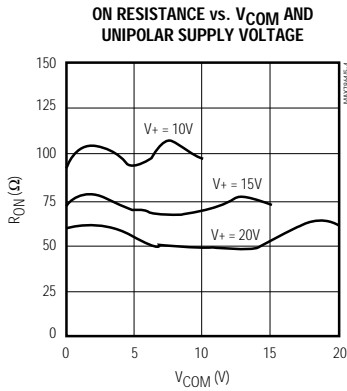
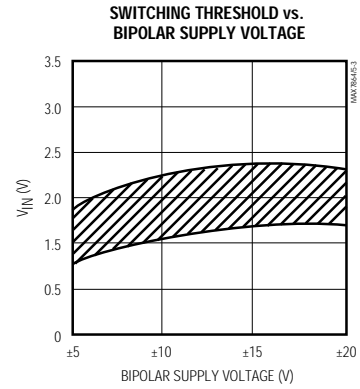
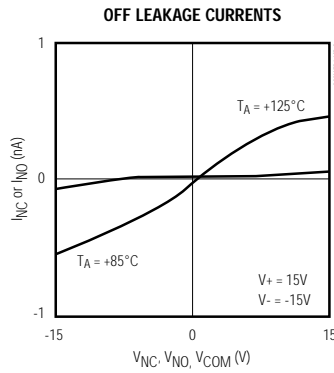
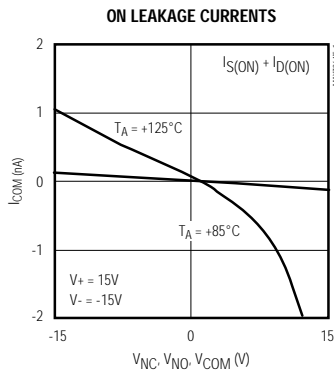

Precision, Quad, SPST Analog Switches

Typical Operating Characteristics

(T_A = +25°C, unless otherwise noted.)

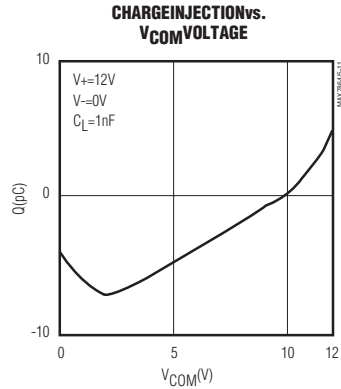
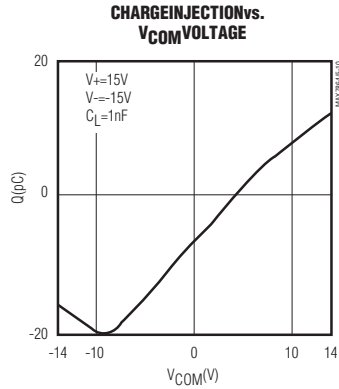

Pin Description

PIN		NAME	FUNCTION
DIP/SO	QFN		
1, 16, 9, 8	15, 14, 7, 6	IN1-IN4	Logic Control Input
2, 15, 10, 7	16, 13, 8, 5	COM1-COM4	Analog-Switch Common Terminal
3, 14, 11, 6	1, 12, 9, 4	NC1-NC4 OR NO1-NO4	NC (normally closed, MAX364) NO (normally closed, MAX365) Analog-Switch Terminal
4	2	V-	Negative Supply-Voltage Input
5	3	GND	Ground
12	10	VL	Logic Supply-Voltage Input
13	11	V+	Positive Supply Voltage Input—connected to substrate

Precision, Quad, SPST Analog Switches

MAX364/MAX365

Applications Information

Application Hints

1. Switches are open when power is off.
2. IN₋, COM₋, NO₋, and NC₋ should not exceed V₊ or V₋, even with the power off.
3. Switch leakage is from each analog switch terminal to V₊ or V₋, not to the other switch terminal.

Operation with Supply Voltages Other than ±15V

The main limitation of supply voltages other than ±15V is reduction in the analog signal range. The MAX364/MAX365 switches operate with ±5V to ±20V bipolar supplies. The *Typical Operating Characteristics* graphs show typical on resistance for ±15V, ±10V, and ±5V supplies. Switching times increase by a factor of two or more for ±5V operation. The MAX364/MAX365 operate from unipolar supplies of +10V to +24V. Both parts can be powered from a single +10V to +24V supply, as well as from unbalanced supplies, such as +24V and -5V. Connect V₋ to 0V when operating with a single supply. VL must be connected to +5V to be TTL compatible or to V₊ for CMOS logic input levels.

Overvoltage Protection

Proper power-supply sequencing is recommended for all CMOS devices. It is important not to exceed the absolute maximum ratings, because stresses beyond those listed may cause permanent damage to the devices. Always sequence V₊ on first, followed by VL, V₋, and logic inputs. If power-supply sequencing is not possible, protect the devices from overvoltage by

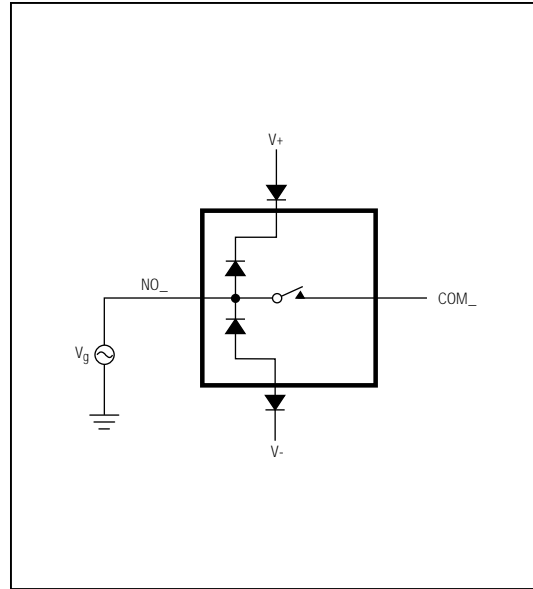

Figure 1. Overvoltage Protection Using Blocking Diodes

adding two small signal diodes in series with the supply pins (Figure 1). Adding the diodes reduces the analog signal range to 1V below V₊ and 1V below V₋, but low switch resistance and low leakage characteristics are unaffected. Device operation is unchanged, and the difference between V₊ to V₋ should not exceed +44V.

Precision, Quad, SPST Analog Switches

Test Circuits/Timing Diagrams

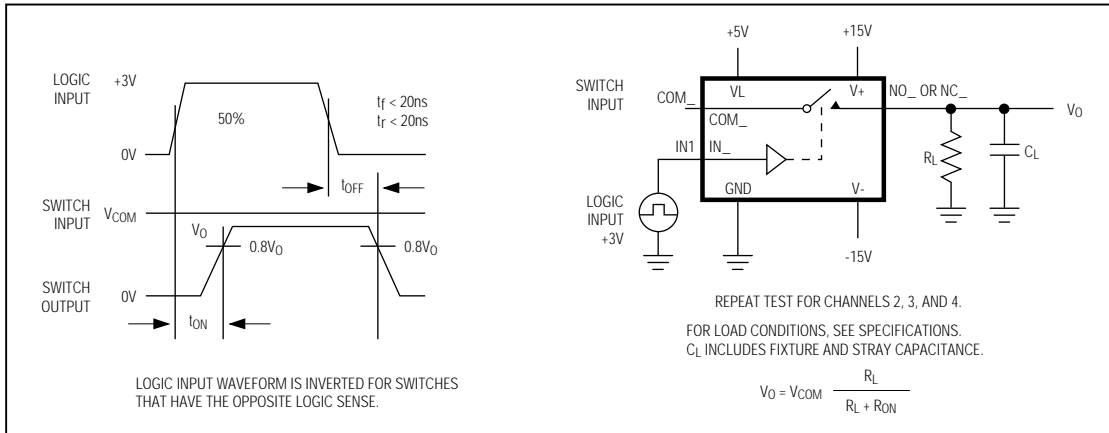

Figure 2. Switching-Time Test Circuit

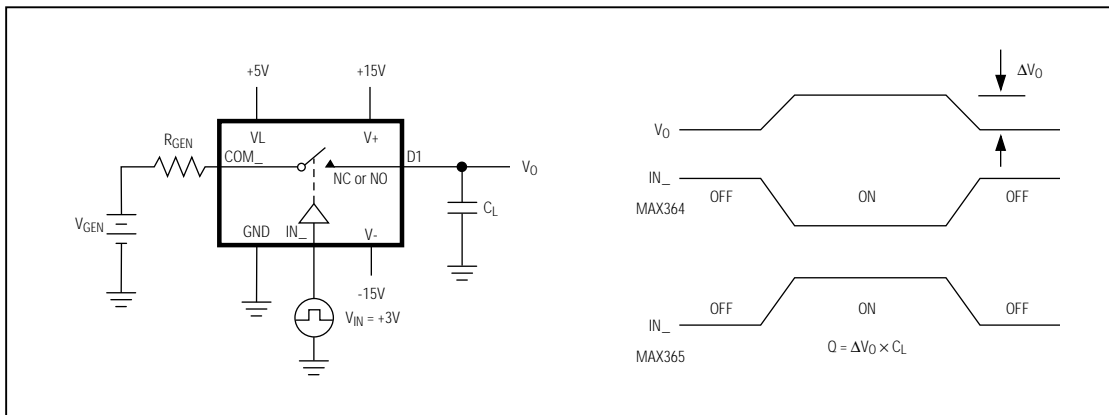

Figure 3. Charge-Injection Test Circuit

Precision, Quad, SPST Analog Switches

Test Circuits/Timing Diagrams (continued)

MAX364/MAX365

FREQUENCY TESTED	SIGNAL GENERATOR	ANALYZER
100Hz to 13MHz	AUTOMATIC SYNTHESIZER	SPECTRUM ANALYZER

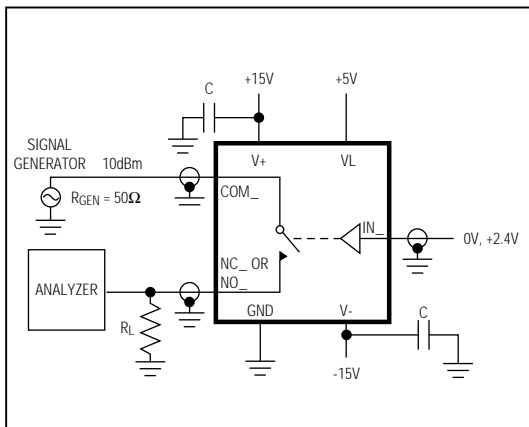

Figure 4. Off Isolation Test Circuit

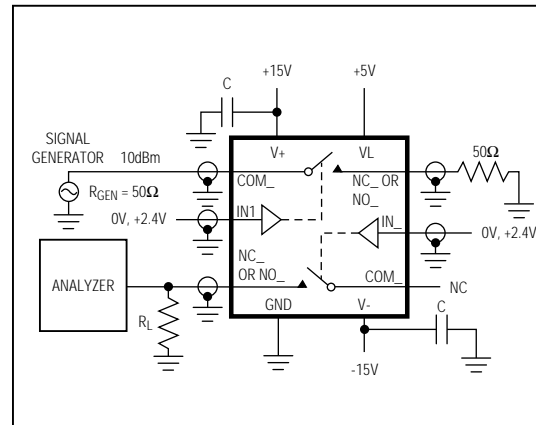

Figure 5. Crosstalk Test Circuit

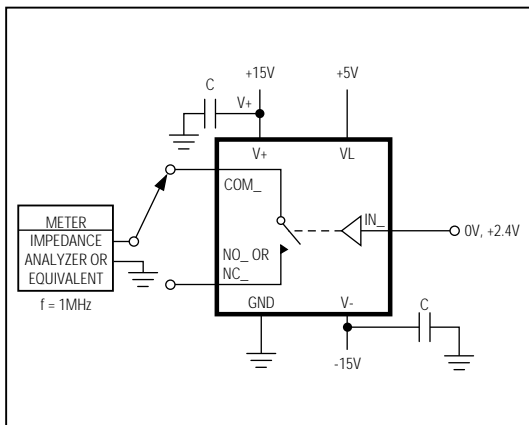

Figure 6. COM_, NC_, NO_ Off Capacitance

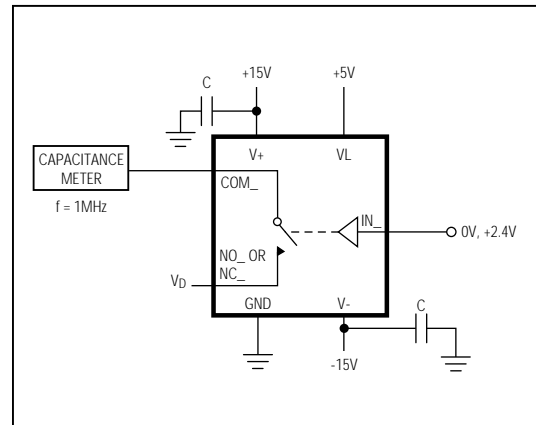
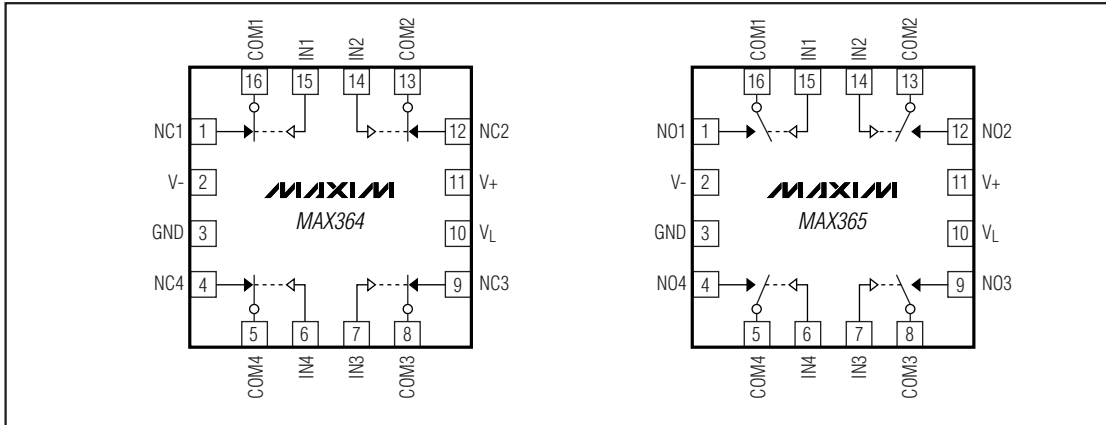

Figure 7. COM_, NC_, NO_ On Capacitance

Precision, Quad, SPST Analog Switches

MAX364/MAX365

Pin Configurations



Chip Topography

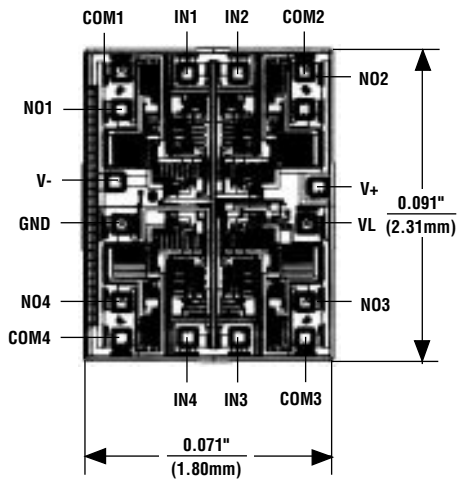

TRANSISTOR COUNT: 126;
SUBSTRATE CONNECTED TO V+.

Precision, Quad, SPST Analog Switches

MAX364/MAX365

Package Information (continued)

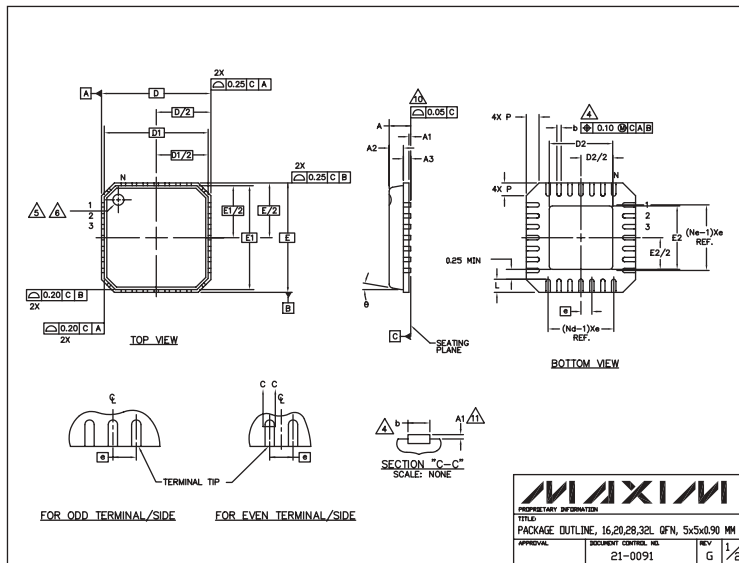

32L QFN LEFS

NOTES:

- DIE THICKNESS ALLOWABLE IS 0.305mm MAXIMUM (.012 INCHES MAXIMUM)
- DIMENSIONING & TOLERANCES CONFORM TO ASME Y14.5M. - 1994.
- N IS THE NUMBER OF TERMINALS.
Nd IS THE NUMBER OF TERMINALS IN X-DIRECTION &
Ne IS THE NUMBER OF TERMINALS IN Y-DIRECTION.
- △ DIMENSION b APPLIES TO PLATED TERMINAL AND IS MEASURED BETWEEN 0.20 AND 0.25mm FROM TERMINAL TIP.
- △ THE PIN #1 IDENTIFIER MUST BE EXISTED ON THE TOP SURFACE OF THE PACKAGE BY USING INDENTATION MARK OR INK/ LASER MARKED.
- △ EXACT SHAPE AND SIZE OF THIS FEATURE IS OPTIONAL.
- ALL DIMENSIONS ARE IN MILLIMETERS.
- PACKAGE WARPAGE MAX 0.05mm.
- △ APPLIED FOR EXPOSED PAD AND TERMINALS. EXCLUDE EMBEDDED PART OF EXPOSED PAD FROM MEASURING.
- MEETS JEDEC MO220.
- THIS PACKAGE OUTLINE APPLIES TO ANVIL SINGULATION (STEPPED SIDES) AND TO SAW SINGULATION (STRAIGHT SIDES) QFN STYLES.

COMMON DIMENSIONS				
Symbol	MIN	NOM	MAX	Notes
A	0.80	0.90	1.00	
A1	0.93	0.91	0.95	
A2	0.00	0.65	1.00	
A3		0.20	REF.	
D		5.00	BSC	
D1		4.75	BSC	
D2		5.00	BSC	
E		4.75	BSC	
b	0"	-	12"	
P	0	-	0.60	
D2	1.25	-	3.25	
E2	1.25	-	3.25	

PITCH VARIATION B				PITCH VARIATION B				PITCH VARIATION C				PITCH VARIATION D				
Symbol	MIN	NOM	MAX	Symbol	MIN	NOM	MAX	Symbol	MIN	NOM	MAX	Symbol	MIN	NOM	MAX	
B	18	0.80	BSC	B	20	0.65	BSC	C	28	0.50	BSC	D	32	0.50	BSC	
Nd	4			Ne	5			Nd	7			Ne	8			
Nd	3	0.35	0.55	0.75	3	0.35	0.55	0.75	3	0.35	0.55	0.75	3	0.30	0.40	0.50
Ne	4	0.28	0.33	0.40	4	0.23	0.28	0.35	4	0.18	0.23	0.30	4	0.18	0.23	0.30

MAXIM
 PROPRIETARY INFORMATION
 TITLE: PACKAGE OUTLINE, 16,20,28,32L QFN, 5x5x0.90 MM
 APPROVAL: DOCUMENT CONTROL, NO. 21-0091 REV. G 2/2

Maxim cannot assume responsibility for use of any circuitry other than circuitry entirely embodied in a Maxim product. No circuit patent licenses are implied. Maxim reserves the right to change the circuitry and specifications without notice at any time.

12 **Maxim Integrated Products, 120 San Gabriel Drive, Sunnyvale, CA 94086 (408) 737-7600**

© 2001 Maxim Integrated Products Printed USA **MAXIM** is a registered trademark of Maxim Integrated Products.